

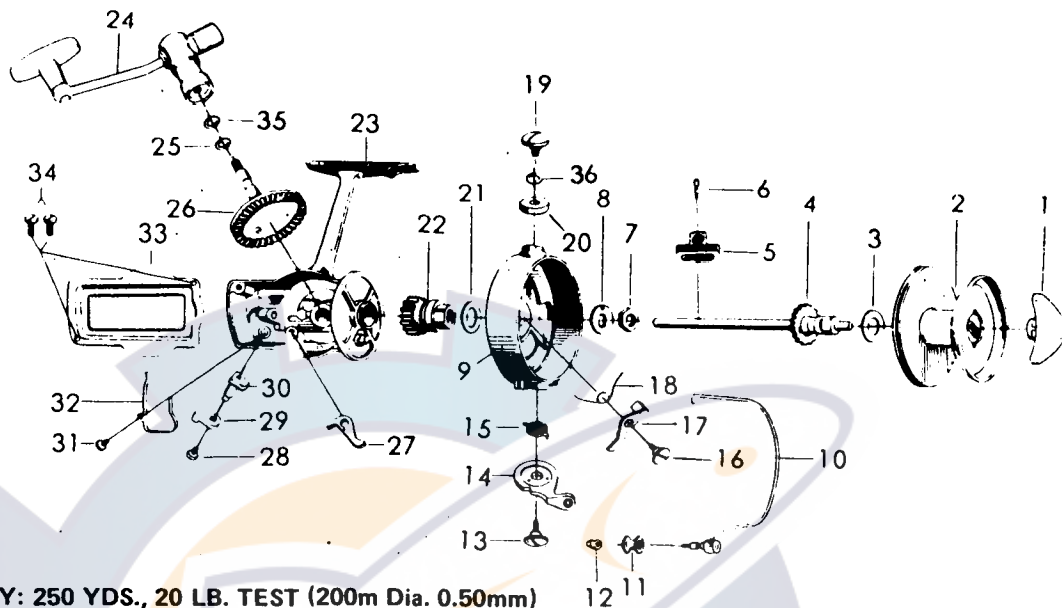

SPINNING REEL 7700A



LINE CAPACITY: 250 YDS., 20 LB. TEST (200m Dia. 0.50mm)

Key No.	Parts No.	Parts Name	Key No.	Parts No.	Parts Name
1	60058802	Drag knob	26	64129301	Drive gear
2	67308301	Spool assembly	27	61101641	Anti-reverse claw
3	63746302	Spool washer	28	63501931	Anti-reverse lever screw
4	67105701	Main shaft	29	65401311	Anti-reverse lever
5	64810101	Oscillating slider	30	64611601	Anti-reverse cam
6	61216401	Oscillating slider pin	31	63522201	Anti-reverse spring screw
7	63408301	Rotor nut	32	61503361	Anti-reverse spring
8	63748101	Rotor retaining washer	33	60069301	Body cover
9	67352801	Rotor	34	63516601	Body cover screw
10	60028611	Bail	35	63710602	Handle washer
11	62501501	Line roller	36	63714501	Bail holder washer
12	63408501	Bail nut			
13	63631601	Arm lever screw			
14	62301861	Arm lever			
15	61438301	Bail spring			
16	63631501	Bail kick lever screw			
17	65709301	Bail kick lever			
18	61406231	Bail kick lever spring			
19	63631601	Bail holder screw			
20	66303601	Bail holder cap			
21	63709820	Pinion washer			
22	64021301	Pinion			
23	67004001	Body			
24	67457801	Handle			
25	63709920	Drive gear washer			

Darwa

Page
32

Date
12-75

Rev. No.
00